



hands free hygiene
clean hands, safe hands

Wall Outlet Tapware (Remote)

Electronic hands-free tapware, Bluetooth® enabled



Hands Free Hygiene

P: 1800 782 088 | sales@handsfreehygiene.com.au

Handsfreehygiene.com.au

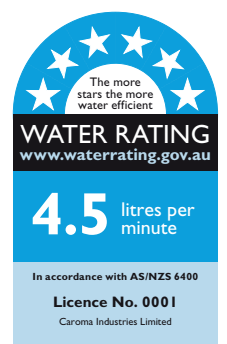

Wall Outlet Tapware (Remote)



Chrome version

- Responsive infrared sensing electronic basin (hob) mounted tap design for commercial applications.
- Reassurance LED upon activation. Configurable to three separate colour modes (Cold/Warm/Hot).
- Enhanced self-configuring features which assist the sensors to understand the surrounding surfaces.
- Easy access to servicable components.
- Bluetooth® enabled for direct access from a smart device and also communication to Gateway*
- Smart device application enables faster commissioning and maintenance.
- Complete with Flow Control box and Power supply.

Outlet: Flowrate: 3.5 Litre per minute. WELS 6 Star.

Hygienic Flush: Hygienic flush every 24 hours (optional).

Electronic Valve: The operating voltage of the valve is 6 volts DC.

Electronics: Supply voltage to the system is 240V AC 50Hz. Operating current 6 volts DC. Single Temperature, Male DN15 (G1/2") water connection.

Installation: For general electrical connection install a plug socket 240V AC.

Dimensions: All dimensions are in millimetres and are subject to normal manufacturing variations. Caroma pursues a policy of continuing improvement in design and performance of its products. The right is therefore reserved to vary specifications without notice.

Smart Command™ Wall Outlet Remote Tapware

	Code No.
Chrome	98492C6A
Black	98492B6A
Gunmetal	98492GM6A
Brushed Nickel	98492BN6A
Brushed Brass	98492BB6A
Rough-In Kit	98469

Also available in the following colour options:



Black



Gunmetal



Brushed Nickel

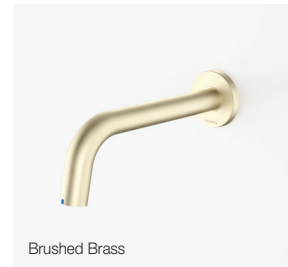

Brushed Brass

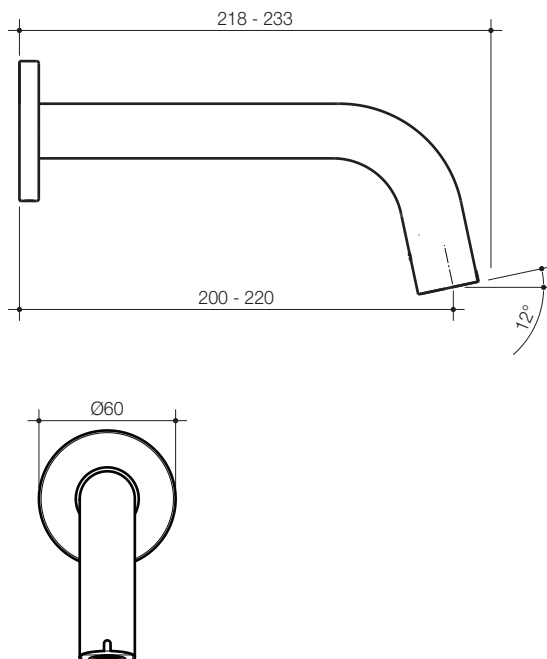

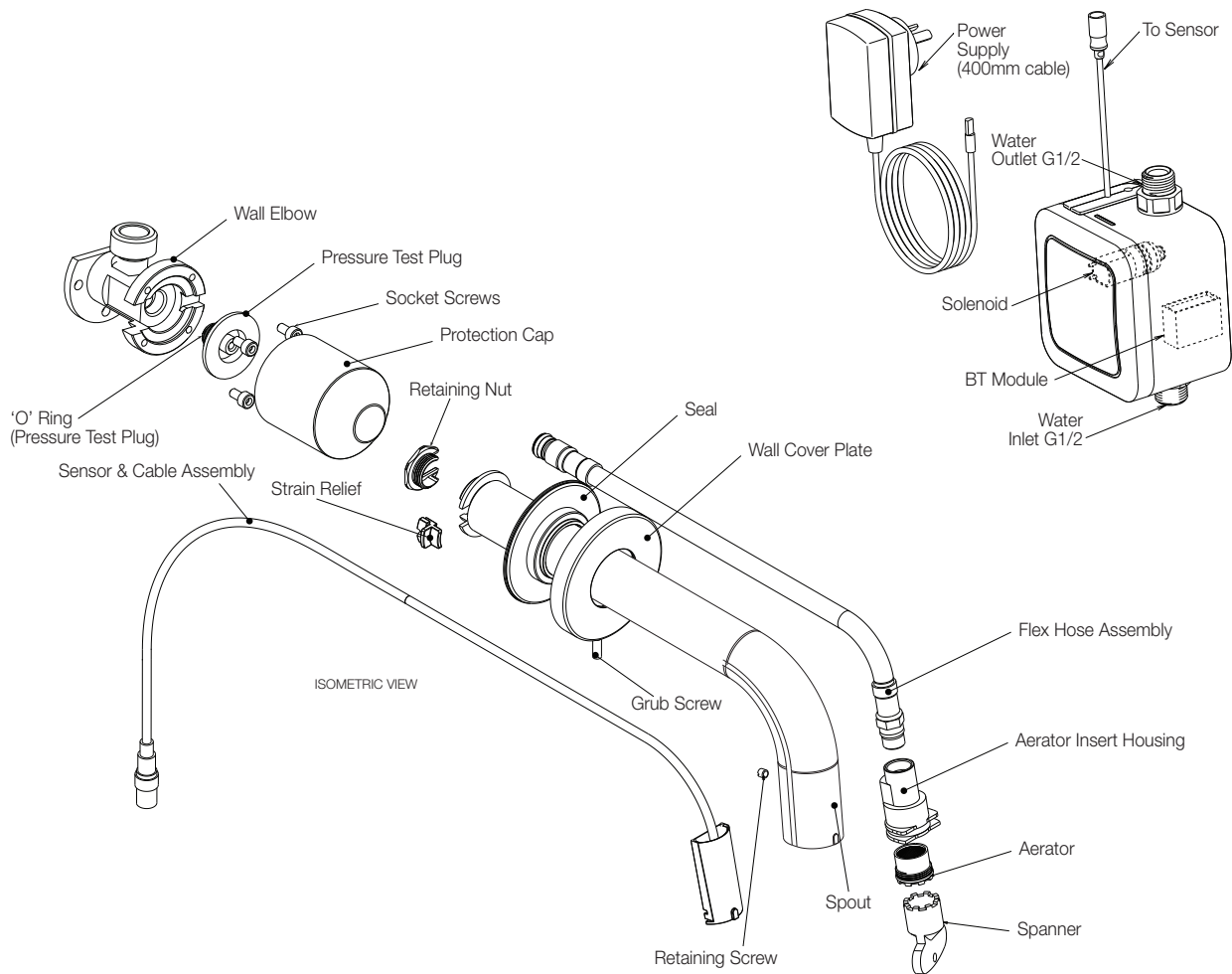

Figure 2: Product Assembly

Technical Data Wall Outlet (Remote)	
Ethernet Gateway Dimensions	Width 211mm x Distance to Centre of Outlet: 236mm x Height: 50mm
Weight	650g
Power Supply	Wall mounted power pack (supplied)
Sensor Type	Infra-Red
Power Consumption	Max. 20mA
Plug Pack Input	240V AC 50/60 Hz
Plug Pack Output	6V DC
Ambient Temperature	0°C...60°C
BMS Connection Type	BMS Connection via Caroma Smart Command connective hardware
Communication Protocol	Bluetooth 4.0
Power Supply EMC Approvals	CE, C-Tick and FCC
Power Supply Safety Approvals	RCM, UL, CUL, TUV, GS, SAA, CE and CB
Power Supply Safety Compliance	AS/NZS 60950, UL 60950, EN 60950, IEC 60950
ROHS Compliance	EN50581:2012
EMC Compliance	EN 301 489-1 V2.1.1, EN 300 328 V2.1.1, EN623111, EN62368-1: 2014, AS/NZS CISPR 32:2015 (ITE Class B)
Electrical Safety Compliance	IEC 60950-1, UL 60950-1, CSA C22.2 60950-1
Complies with EC Directives	RoHS2 Directive 2011/65/EU, Waste Electrical and Electronic Equipment (WEEE) Directive 2002/96/EC, Registration, Evaluation, Authorisation and Restriction of Chemicals (REACH) Directive, Conflict Minerals Directive
Packaging	Dimensions: H: 250 mm x L: 350 mm x D: 100 mm Weight: 900 g Quantity: 1