

Flowmatic® Hob Basin Tap Battery Power Single Temperature

Specification Data Sheet



Features

- Hands free/touch-free, electronically controlled sensor activated.
- Polished chrome plated with a sturdy metal housing.
- Powerful solenoid valve and water efficient aerator.
- Single temperature. Adjustable temperature (hot & cold) option available.
- Check valves and built in filters standard.
- Temporary-off and continuous-on options to suit specific client requests.
- Hygienic rinse water flow time adjustable to comply with health standards with adjustable 12, 24 or 72 hour hygienic rinse option.
- Easy installation similar to conventional single lever mixer tap.

To Specify

Flowmatic® Electronic tapware is a technologically advanced range of hands free tapware designed to reduce the risk of disease caused by contamination when operating tapware and flushing systems. The range is ideal for health care facilities, food preparation areas in hotels and restaurants and care facilities where patients suffer with arthritis. Flowmatic® tapware and valves play an important role in reducing water and energy consumption.

Code:

TZ-FLOWHOBSB - Flowmatic Hob Basin Tap Battery Power Single Temperature.

Hands Free Hygiene

Ph: 1800 039 764

sales@handsfreehygiene.com.au

handsfreehygiene.com.au



hands free hygiene
clean hands, safe hands

Performance Standards & Approvals

- AS/NZS 3718 - Watermark
- WELS 6 Star Rating



Typical Dimensions

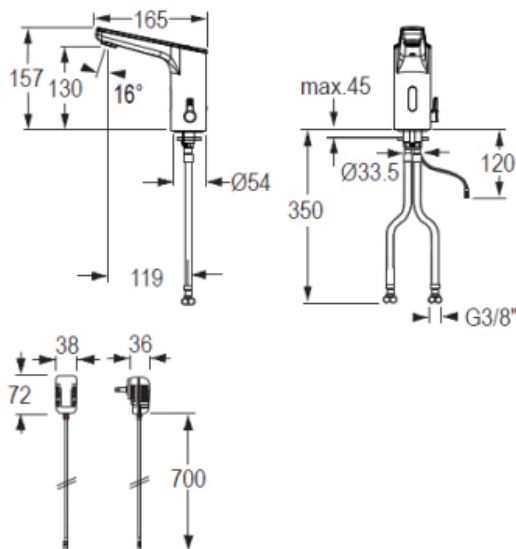

Fig 1. Dimensional illustration

Technical Information

- Operating pressure: 30kPa - 1000kPa
- Maximum water temperature: 80°C
- Aerator: Economy aerator, cascade (self-cleaning)
- Inlet connections: 350mm long flexible hoses
- Strainers: 0.5mm mesh size
- Sensor-sensitivity: Automatic self-adapting sensor
- Hygienic rinse: Adjustable with touch from 30 sec - 20 min
- Temporary-off: 2 minutes (fixed)
- Continuous water flow: 2 minutes present (Adjustable with touch 30 sec - 20 min)
- Power supply: 6V Lithium CPR 2 Battery
- Engineering standards: DIN EN 200; CE
- Finish: Chrome

Maintenance & Cleaning

Galvin Specialised products should be cleaned with a soft damp cloth using only mild liquid detergent or soap and water. Do not use cleaning agents containing a corrosive acid, scouring agent or solvents. Do not use cream cleaners, as they are abrasive. Use of unsuitable cleaning agents may damage the surface. Any damage caused in this way will not be covered by warranty.

Regular maintenance should be carried out in accordance with the installation and troubleshooting guides provided with the product, relevant Australian Standards, local authorities and state codes.

As part of maintaining a safe and reliable plumbing system, we recommend tapware and valves are operated on at least a daily basis.

Warranty

Galvin Specialised products are covered under our Manufacturer's Warranty at www.galvinengineering.com.au. Galvin Specialised products must be installed in accordance with the installation instructions and in accordance with AS3500 and the PCA, relevant Australian Standards and local authorities applicable to product being installed. Water and electrical supply conditions must also comply to the applicable national and/or state standards, failing to comply with these provisions may void the product warranty and affect performance of the product.

Hands Free Hygiene

Ph: 1800 039 764

sales@handsfreehygiene.com.au

handsfreehygiene.com.au

